

amequipment.com
 Phone: (541) 327-1546
 FAX: (541) 327-1548

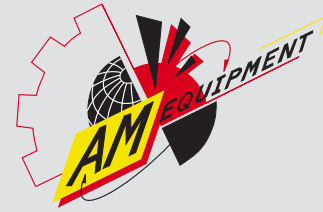

M1

Metro 1 heavy duty unitized assembly

- Heavy duty applications
- Assembly includes motor, bracket, linkage, and shaft, assembled to order
- For 22" to 36" (550mm to 900mm) wiper arms
- For wiper blades up to 32" (812mm)
- 12 and 24 motor voltages available
- 30 Nm stall torque
- Two speed
- Standard dynamic braking
- Available in "mirrored" brackets mountable in any position (see diagrams below)

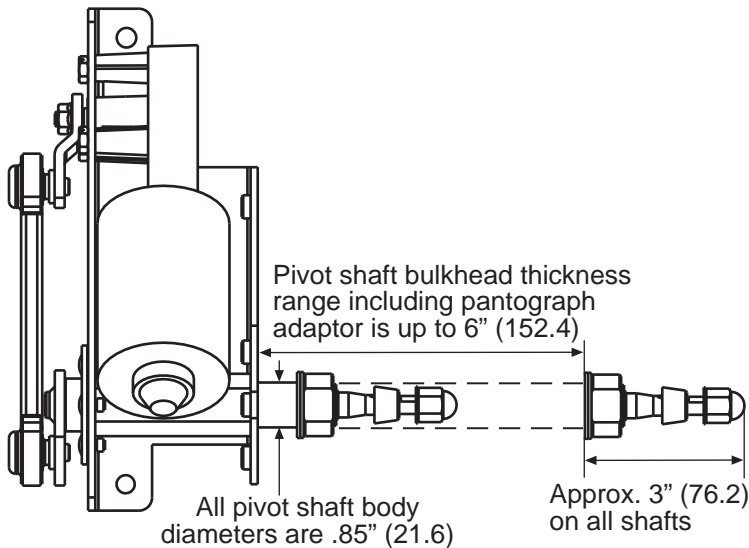

TOP VIEW

Pantograph adapters

- Allow use of a pantograph wiper arm (double arm) on Metro unitized assembly
- Works with Metro series wiper motor systems
- Available with or without a brass washer fluid connector tube

