

2

1

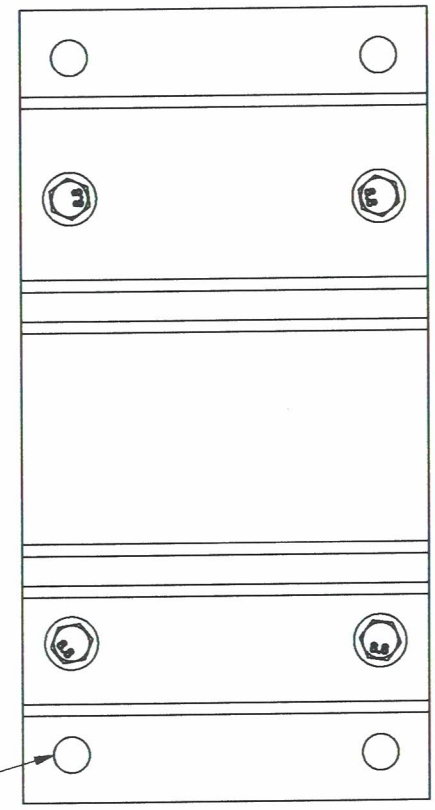
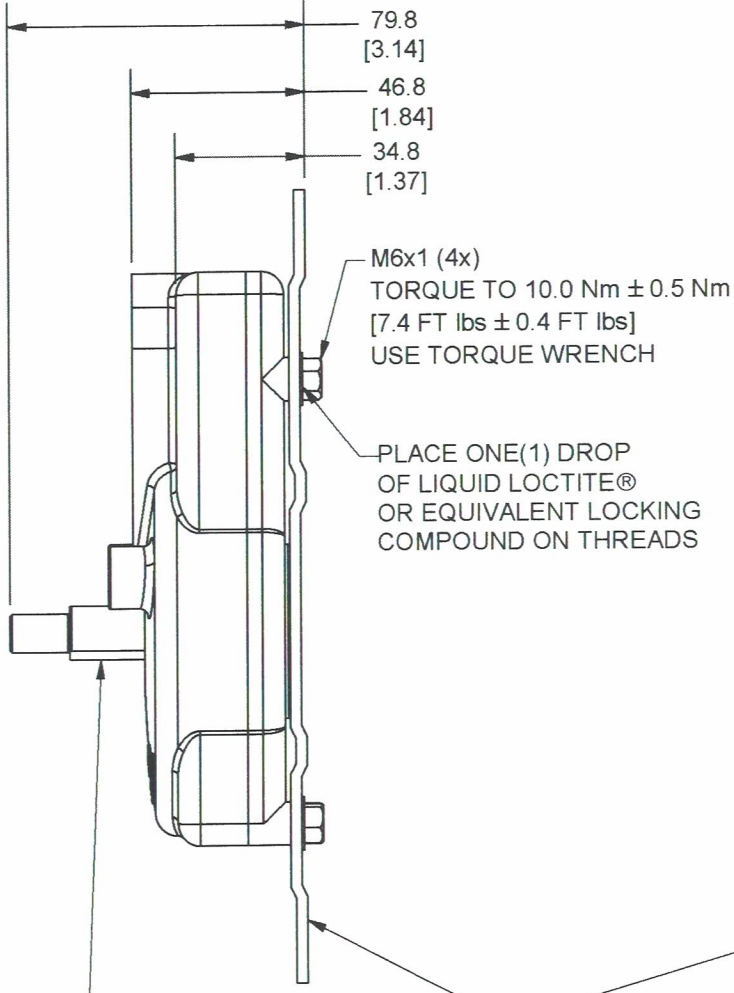
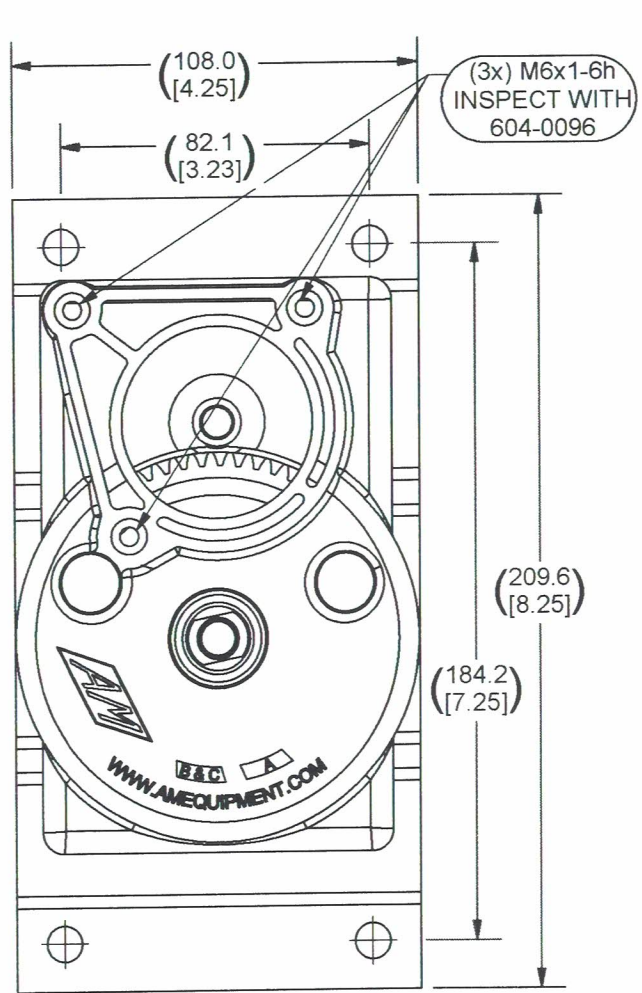

SHAFT TO TURN FREELY AFTER ASSEMBLY
 USE SHAFT #420-1046 & PINION #412-1075
 TO ENSURE THAT SHAFT #420-1044 TURNS
 FREELY WITHOUT BINDING OR ROUGHNESS

ENSURE BRACKET IS ORIENTED
 CORRECTLY TO GEARBOX.

B

B

A

A

Dimensions are in:
MM [INCHES]

Project 818-0034	Drafted by CW 2/5/2004	Revised by RW 3/21/2019	Checked by RR 3/21/2019	Approved by AS 3/21/2019	Material Specification N/A	Finish Specification N/A		
OVALS ARE FOR INCOMING INSPECTION CHECKING PROCESSES	UNLESS OTHERWISE SPECIFIED				<p>402 E Hazel P.O. Box 790 Jefferson, OR 97352 amequipment.com</p>	Title/Name Assy, Gearbox, 5:1		
	TOLERANCES IN INCHES MM 1 PLACE DEC. = N/A ±0.25 2 PLACE DEC. = ±0.01 ±0.13 3 PLACE DEC. = ±0.005 ±0.08 4 PLACE DEC. = ±0.0025 N/A ANGULAR DIM. = ±1° ±1° DO NOT SCALE DRAWING WORK TO GIVEN DIMENSIONS					Part Number 110-1025	Revision 9	Sheet 1 OF 2
	THIS DRAWING IS THE SOLE PROPERTY OF AM EQUIPMENT AND CANNOT BE REPRODUCED IN ANY WAY WITHOUT THE EXPRESS WRITTEN PERMISSION OF AM EQUIPMENT					3/21/2019		

2

1

2

1

Parts List			
ITEM	QTY	PART #	DESCRIPTION
1	4	414-1150	Screw, HHCS, 10mm Flats, M6x1, 25mm Threads, Serrated
2	1	306-1213	Bracket, Gearbox
3	1	429-1014	Housing, Gearbox 5:1, Bottom Cover
4	2	416-1038	Bearing, 40mm OD, 6203-2RS
5	1	420-1044	Shaft, Output, 12mm DoubleFlat 17mm OD, 72mm OAL
6	1	412-1050	Gear, 60 Teeth, 16 DP, 92.25mm PD, Zinc
7	1	429-1013	Housing, Gearbox 5:1, Top Cover

B

A

A

B

A

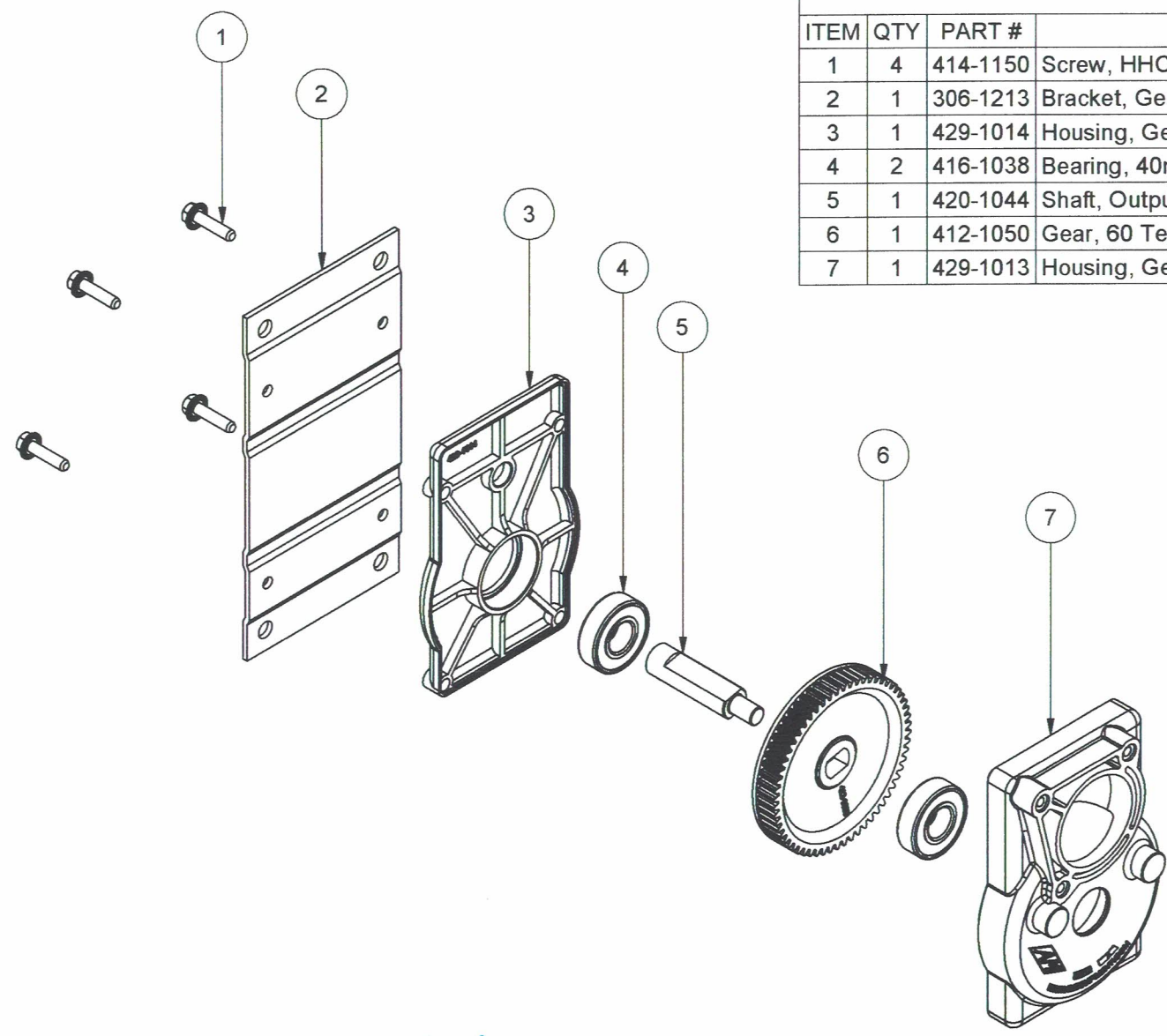

Dimensions are in:
MM [INCHES]

Project 818-0034	Drafted by CW 2/5/2004	Revised by RW 3/21/2019	Checked by RR 3/21/2019	Approved by AS 3/21/2019	Material Specification N/A	Finish Specification N/A
OVALS ARE FOR INCOMING INSPECTION CHECKING PROCESSES	UNLESS OTHERWISE SPECIFIED				 <p>402 E Hazel P.O. Box 790 Jefferson, OR 97352 amequipment.com</p>	Title/Name Assy, Gearbox, 5:1
	TOLERANCES IN INCHES MM 1 PLACE DEC. = N/A ±0.25 2 PLACE DEC. = ±0.01 ±0.13 3 PLACE DEC. = ±0.005 ±0.08 4 PLACE DEC. = ±0.0025 N/A ANGULAR DIM. = ±1° ±1° DO NOT SCALE DRAWING WORK TO GIVEN DIMENSIONS	THIS DRAWING IS THE SOLE PROPERTY OF AM EQUIPMENT AND CANNOT BE REPRODUCED IN ANY WAY WITHOUT THE EXPRESS WRITTEN PERMISSION OF AM EQUIPMENT	Part Number 110-1025	Revision 9 3/21/2019		Sheet 2 OF 2

2

1

1